

SLF1

(D)	MONTAGEANLEITUNG:	FALTTÜR 2-TEILIG
(GB)	INSTALLATION INSTRUCTIONS:	DOOR WITH 2 FOLDING PANELS IN NICHE
(F)	NOTICE DE MONTAGE:	PORTE REPLIABLE MONTEE EN NICHE
(CZ)	NÁVOD K MONTÁŽI:	DVOUDÍLNÉ SKLÁDACÍ DVEŘE DO NIKY
(PL)	INSTRUKCJA MONTAŻU:	DRZWI SKŁADANE DWUCZĘŚCIOWE
(SK)	NÁVOD NA MONTÁŽ:	DVOJDIELNE SKLADACIE DVERE DO NIKY
(H)	SZERELÉSI ÚTMUTATÓ:	KÉTRÉSZES CSUKLÓAJTÓ
(E)	INSTRUCCIONES DE MONTAJE:	PLEGABLE, 2 PIEZAS
(RO)	INSTRUCȚIUNI DE MONTAJ:	UȘĂ PLIABILĂ DIN 2 PIESE



 **SanSwiss**[®]
RONAL GROUP

Benötigtes Werkzeug:
 Necessary tools:
 Outil Nécessaire:
 Nářadí potřebné pro montáž:

Potrzebne narzędzia:
 Potrebne náradie:
 Szükséges szerszámok:
 Herramientas necesarias:

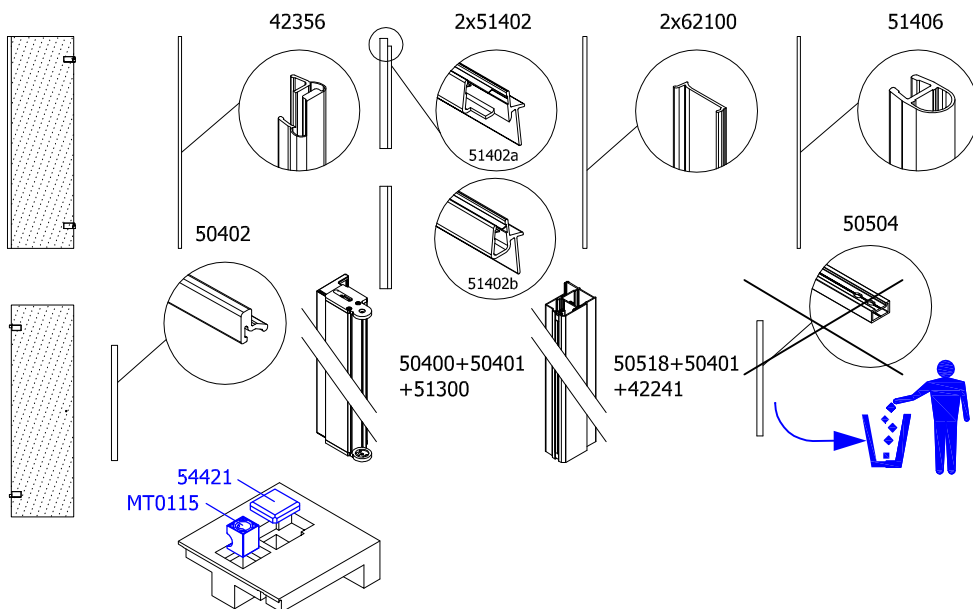
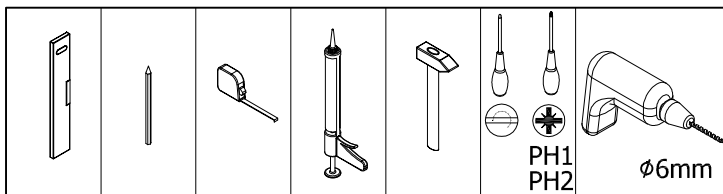

Zubehör:
 Equipment:
 Accessoires:
 Příslušenství:

Dodatki:
 Príslušenstvo:
 Alkatrészek:
 Accesorios:

 1 x 11221	 2 x 14016 3.5 x 22mm	 1 x 14019 3.5 x 16mm	 1 x 14027 M4 x 25mm	 6 x 14118 4.2 x 32mm	 6 x 16000 Ø 6mm
 1 x 51232+1 x 51233	 4 x 51317	 1 x 51695+1 x 51696	 1 x 51796+1 x 51797	 1 x 51798+1 x 51799	 1 x 54401
 1 x MT0114	 8 x 54164	 1 x 17157			

1.

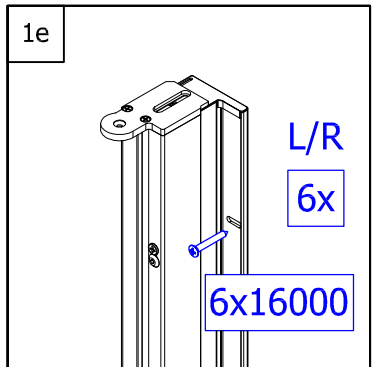
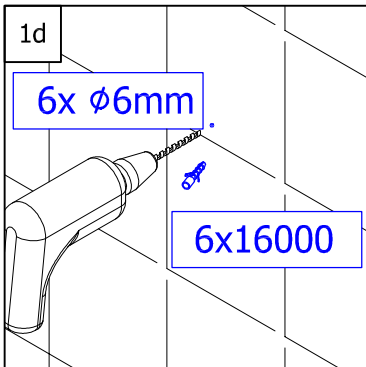
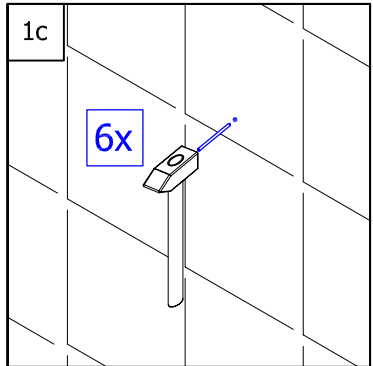
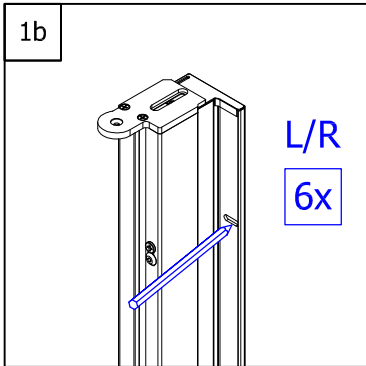
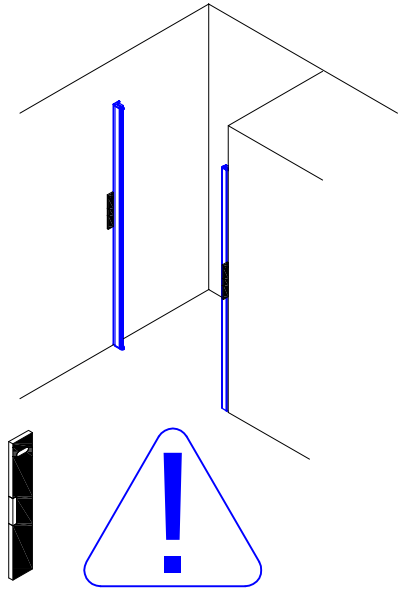
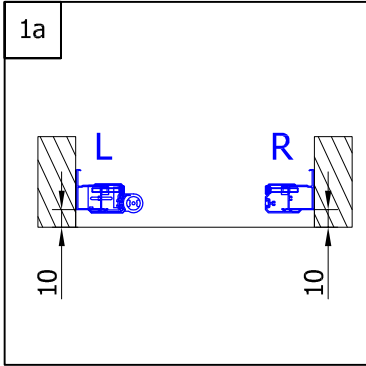

2.

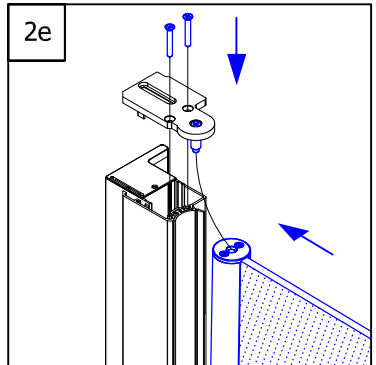
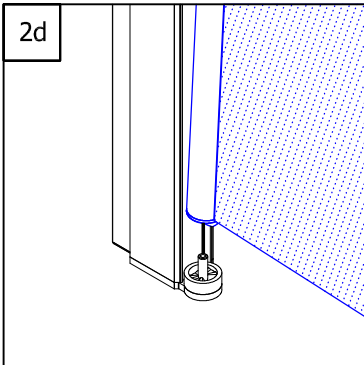
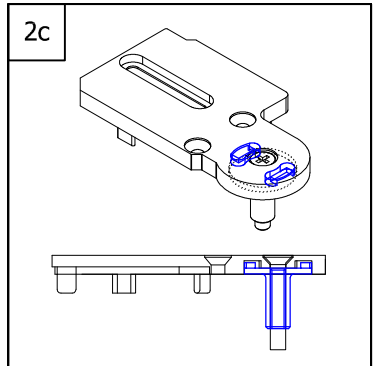
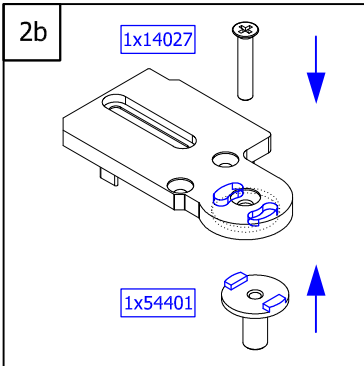
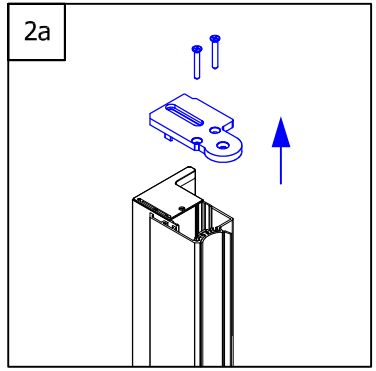
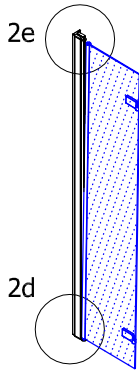

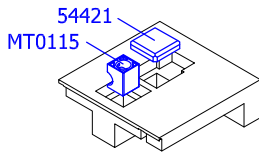
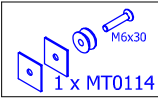

3.

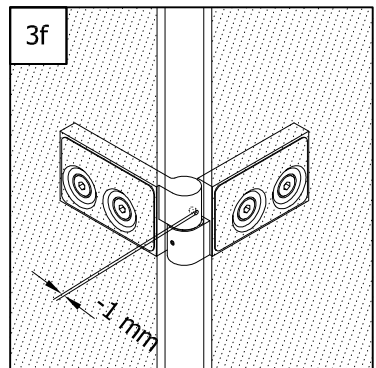
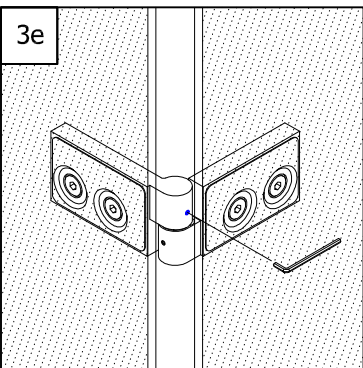
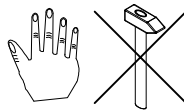
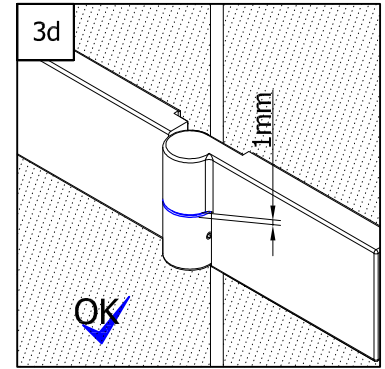
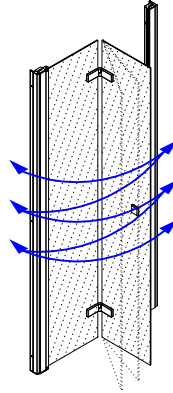
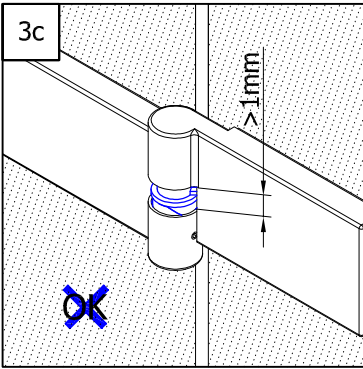
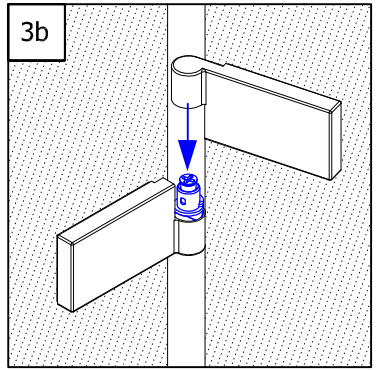
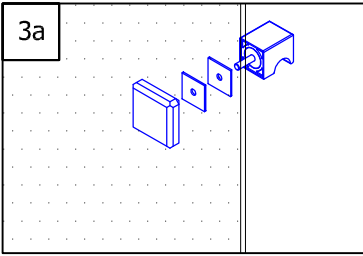

4a

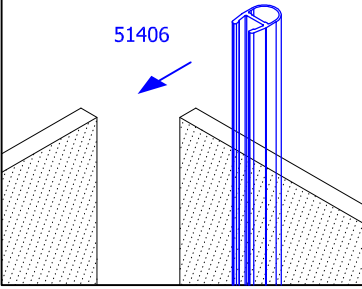

4b

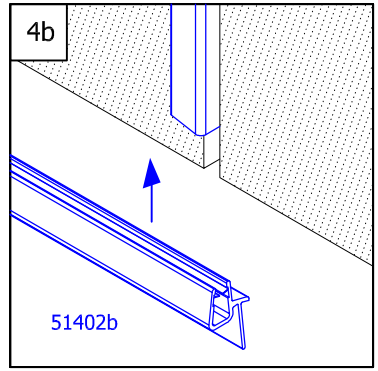

4.

4c

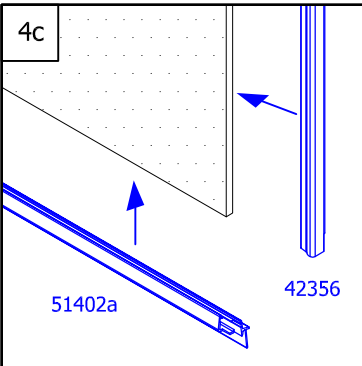

4d

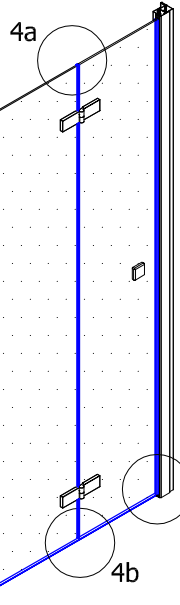
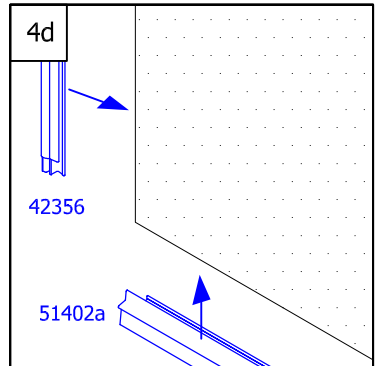

R/L 42356

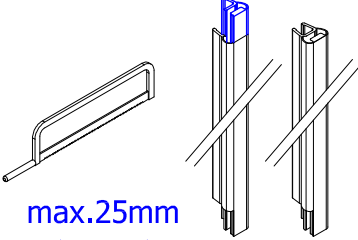

max.25mm

max.25mm

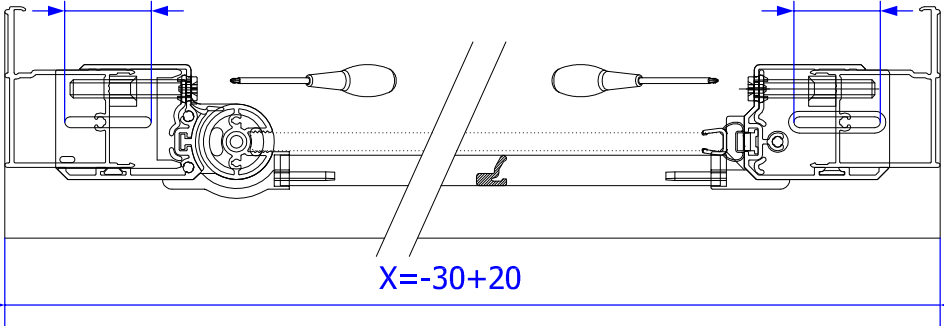

X = -30 + 20

5.

5a

1x14016

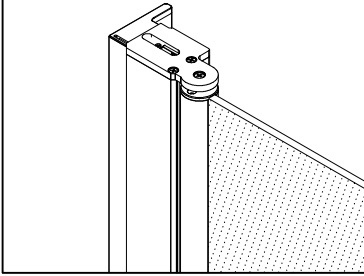

5a

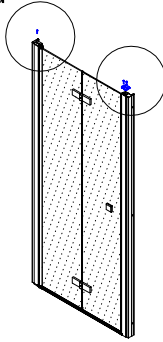

5b

1x14019

1x14016

1x51232/33

1x51798/99

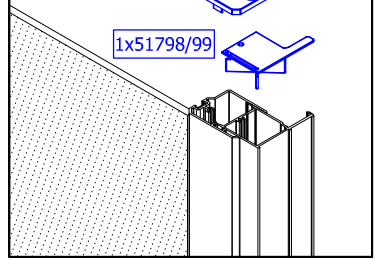

R/L

5c

2x62100

4x51317

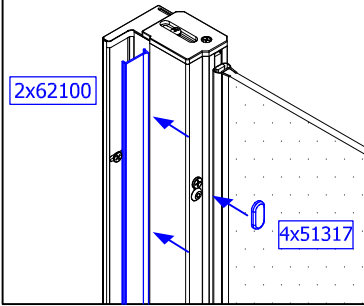

2x62100

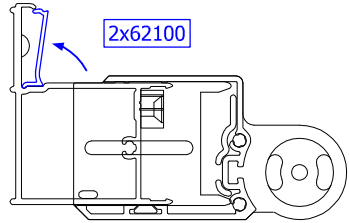

R/L

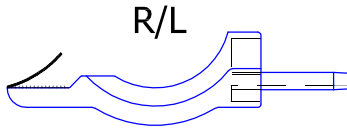

R/L

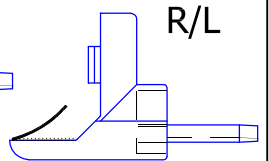

5d

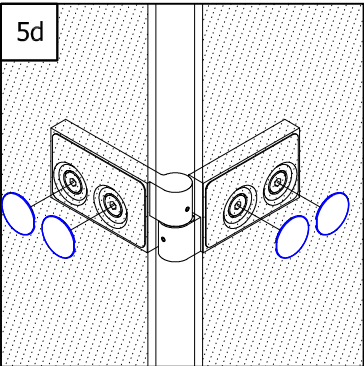

5e

50402

51796/97

51695/96

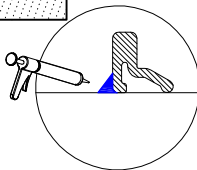
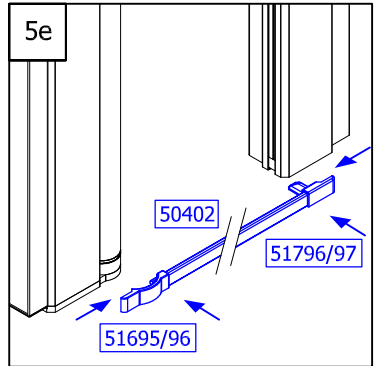
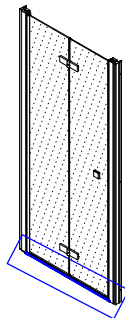

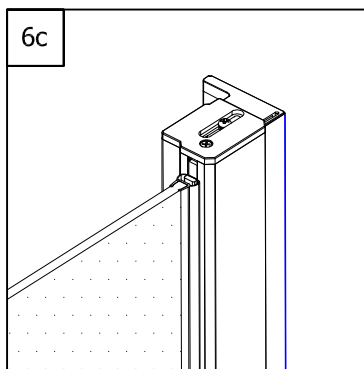
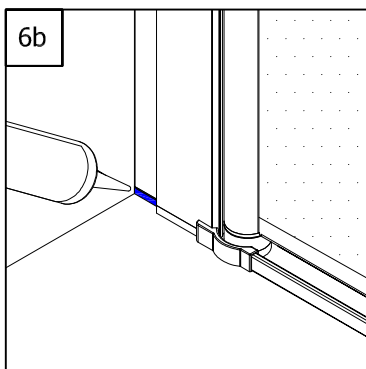
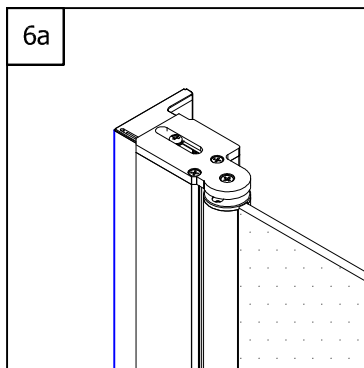
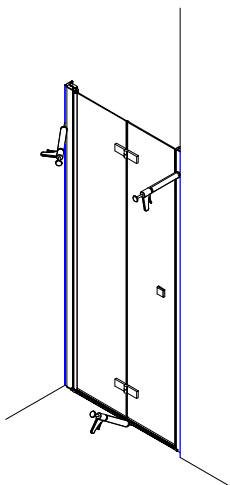

Achtung! Nur Sanitär-Silikon - bakterizid und fungizid eingestellt verwenden.

Caution! Use only bactericidal and fungicide sanitary silicone.

Attention! N'utiliser que du silicone sanitaire bactéricide et fongicide.

Pozor! Používejte pouze baktericidní a fungicidní sanitární silikon.

Uwaga! Stosować tylko silikon sanitarny - bakterio i grzybobójczy.

Pozor! Užívajte pouze baktericidný a fungicidný sanitárny silikón.

Figyelem! Csak szaniter sziloplaszt - baktérium és gombamentes - használata megengedett.

Cuidado! Utilizar solamente silicona sanitaria bactericida y fungicida.

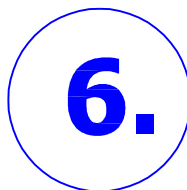
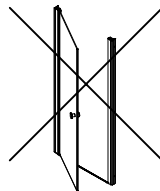
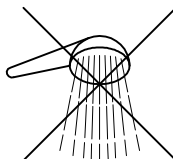

QUALITY CONTROL:

D Falls Sie Reklamationen haben, oder Sie unzufrieden mit Ihrem SANSWISS Produkt sind, beschreiben Sie bitte unten auf diesem Blatt den Produktfehler und übergeben Sie dieses Dokument Ihrem Verkäufer, oder direkt der Firma SANSWISS. Diese Information hilft uns, die Qualität von unseren Produkten weiter zu verbessern.

GB In case of a complaint or Your dissatisfaction with the SANSWISS product, please describe the defect below and pass this document to Your vendor, or directly to the SANSWISS company. This information will help us in the next increase of the quality of our products.

F En cas de réclamations lors de la livraison ou l'installation de votre paroi de douche SANSWISS, veuillez, s'il vous plaît, noter vos remarques au bas de la feuille et transmettre les informations à votre revendeur. Elles nous permettrons d'améliorer notre qualité et par la même notre service.

CZ V případě reklamace, či Vaší nespokojenosti s výrobkem SANSWISS popište prosím ve spodní části tohoto listu závadu a dokument prosím odevzdejte Vašemu prodejci nebo přímo firmě SANSWISS. Tato informace nám pomůže v dalším zvýšení kvality našich výrobků.

PL Reklamacje , oraz inne niezgoności związane z produktem SANSWISS prosimy przekazywac sprzedawcy na załącznym druku.

SK V prípade reklamácie, alebo Vašej nespokojnosti s výrobkom SANSWISS, popište prosím v spodnej časti tohto listu závalu a dokument prosím odovzdajte Vašemu prodejci, alebo priamo firme SANSWISS. Táto informácia nám pomôže v ďalšom zvýšení kvality našich výrobkov.

H Abban az esetben ha reklamációja vagy panasza van az Ön által vásárolt SANSWISS termékkel, úgy azt írja meg a lap alján található helyre és adja át a kereskedőjének, vagy küldje el közvetlenül a SANSWISS cégnek! Ez az információ segít nekünk termékeink minőségének javításában.

E En caso de reclamaciones ó si no está satisfecho con su producto SANSWISS, por favor describan en la parte inferior de esta hoja el fallo del producto y entreguen este documento a su vendedor ó directamente a la empresa SANSWISS. Esta información nos ayuda a seguir mejorando la calidad de nuestros productos.

RO În cazul în care aveți reclamații sau nemulțumiri legate de produsele SANSWISS, vă rugăm să descrieți defecțiunea și să transmiteți acest document vânzătorului sau direct firmei SANSWISS. Această informație ne ajută să îmbunătățim în continuare calitatea produselor noastre.

.....

.....

.....

.....

.....

.....

.....

